

Failure of an Al₂O₃ ceramic under cyclic sphere contact loading

T. FETT, E. ERNST, G. RIZZI

Forschungszentrum Karlsruhe, Institut für Materialforschung II, Karlsruhe

R. OBERACKER

Universität Karlsruhe, Institut für Keramik im Maschinenbau, Karlsruhe

Many ceramics show the effect of cyclic fatigue and mostly the crack growth rate da/dN (a = crack depth, N = number of cycles) can be described by a power law relation

$$\frac{da}{dN} = A \left(\frac{\Delta K}{K_{Ic}} \right)^n \quad (1)$$

with ΔK = variation of the applied stress intensity factor, K_{Ic} = fracture toughness, and the crack growth parameters A and n . If the exponent n is small, the investigated material is very sensitive to cyclic crack growth. For high n -values ($n \rightarrow \infty$), no significant fatigue crack growth effect occurs. Therefore, it is of great importance to know this exponent for a given material.

A simple approach to determining contact strength and lifetime under periodic loading was proposed in [1], where rectangular bars were loaded under line load conditions by a pair of opposite cylinders. An alternative contact strength test under more strongly concentrated contact stresses was based on loading by two opposite spheres [2]. The device applied in [2] was used to determine lifetime under contact loading.

The test device used for the contact strength tests is shown in Fig. 1 [2]. A rectangular bar (1) is loaded via two opposite spheres (2) of radius R , which are loaded by the force P . The load is transferred to the upper sphere by a steel cylinder (3) guided by the hollow cylinder (4). The test can be carried out with simple bending bars ($3 \times 4 \times 45 \text{ mm}^3$) or fragments of shorter length. With this device first strength tests were carried out at a loading rate of 500 N/s.

A commercial alumina, Frialit F99.7 (Friatec, Friedrichsfeld), with a median grain size of $d_m \approx 9 \mu\text{m}$ was tested. In Fig. 2a the load for fracture is plotted in a Weibull representation. The strength data in these tests, of course, are not related to the initial failure distribution and, therefore, not Weibull-distributed. This is the reason why Weibull parameters were not determined. Three series of specimens were loaded periodically at 10 Hz with the ratio of lower (P_{\min}) and upper load (P_{\max}) given by $R = P_{\min}/P_{\max} = 0.05$. Upper loads were chosen as $P_{\max} = 3000, 4000, \text{ and } 5000 \text{ N}$.

Fig. 2b presents the number of cycles to failure N_f in Weibull representation, Fig. 2c is a function of the upper load. The squares in Fig. 2c indicate the median values of cycles to failure. It is a surprising result that the scatter of the number of cycles to failure is very small for each load level. This is in strong contrast to lifetime

results obtained from cyclic bending tests related to natural flaw population. The slope of the straight line is given as $d(\log N_f)/d(\log P_{\max}) = -5.5$. This low value is also in contrast to results obtained for the same material in [3], where a slope of $d(\log N_f)/d(\log P_{\max}) \approx -25$ was found.

First, it is attempted to determine the crack growth exponent n from the measurements of Fig. 2c by application of the well-established stress intensity factor versus crack length relation (for geometric data see Fig. 3). For a relatively short crack length, $c \ll W/2, B/2$, but $c \gg a$ (a = radius of the Hertzian contact area) the relation between the applied load P , the stress intensity factor K_I , and the crack length c is given by [4]

$$K_I = \lambda \frac{P}{c^{3/2}} \quad (2)$$

Under cyclic loading, it therefore holds

$$\Delta K = \chi \frac{P_{\max}(1 - R)}{c^{3/2}} \quad (3)$$

Inserting this into Equation 1 provides the crack growth rate as a function of crack length

$$\frac{dc}{dN} = \frac{A}{K_{Ic}^n} \chi^n (1 - R)^n \frac{P_{\max}^n}{c^{3n/2}} \quad (4)$$

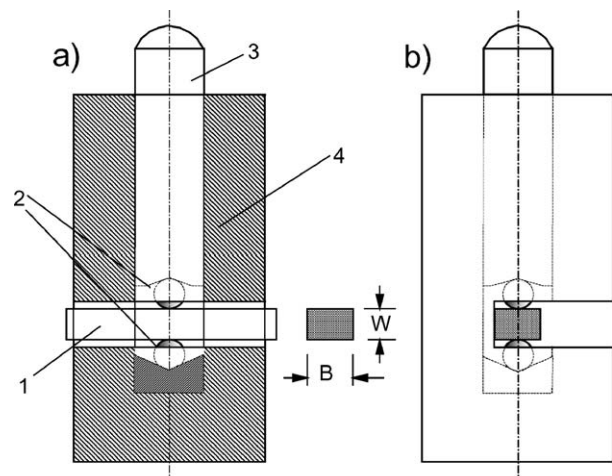

Figure 1 A contact strength test device with two opposite spheres.

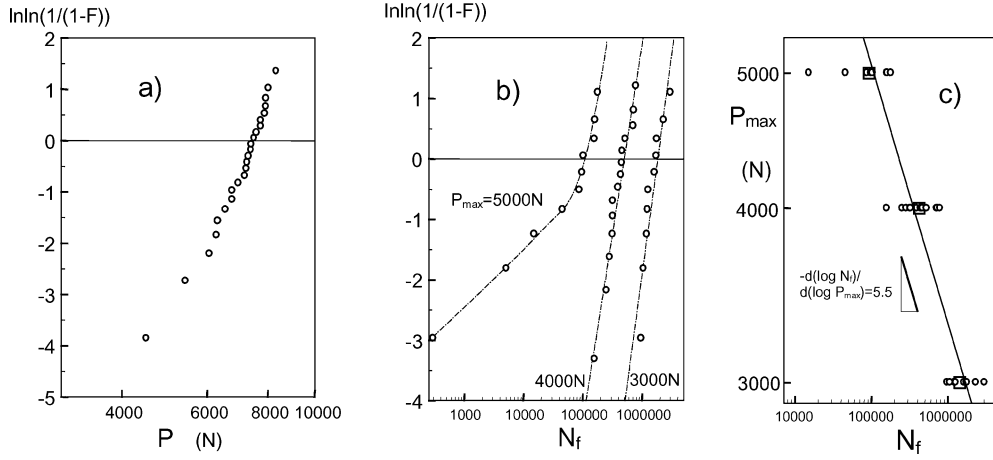

Figure 2 (a) Failure load under monotonously increasing load, (b) number of cycles to failure in Weibull representation, and (c) maximum applied load versus number of cycles (squares: median values).

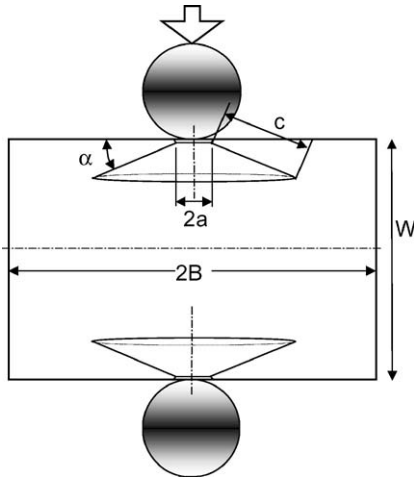

Figure 3 Opposite cone cracks in a rectangular bar (geometric data).

During fatigue, the crack size c increases until failure is obtained for a critical size c_c ,

$$c_c = B/\cos \alpha \quad (5)$$

at which the crack tip reaches the side surface of the test bar. The number of cycles to failure, N_f , results by integration of (4) from the initial crack size c_0 given by

$$c_0^{3/2} = \chi \frac{P_{\max}}{K_{Ic}} \quad (6)$$

to the critical crack size c_c , i.e.,

$$N_f = \frac{K_{Ic}^n}{A\chi^n(1-R)^n P_{\max}^n} \int_{c_0}^{c_c} c^{3/2} dc. \quad (7)$$

This results in

$$N_f = \frac{2}{3n+2} \frac{K_{Ic}^n}{A\chi^n(1-R)^n P_{\max}^n} \left[c_c^{\frac{3}{2}n+1} - c_0^{\frac{3}{2}n+1} \right]. \quad (8)$$

In the considerations made here, the parameter χ was assumed to be a constant. In general, this quantity may

become a function of crack length, since for $c \rightarrow c_c$, the coefficient χ 'feels' the free side faces of the specimen or the opposite crack. In this sense, Equation 8 is an approximation.

In a contact strength test with continuously increasing load, failure occurs at a critical load P_c for which the relation

$$c_c^{3/2} = \chi \frac{P_c}{K_{Ic}} \quad (9)$$

must be fulfilled. Consequently, Equation 8 then reads

$$N_f = \frac{2}{3n+2} \frac{\chi^{2/3}}{A(1-R)^n K_{Ic}^{3/2}} P_{\max}^{2/3} \left[\left(\frac{P_c}{P_{\max}} \right)^{n+\frac{2}{3}} - 1 \right]. \quad (10)$$

For a sufficiently high value of $n + 2/3$ and $P_c < P_{\max}$, it can be approximated $(P_c/P_{\max})^{n+2/3} \gg 1$ and consequently,

$$N_f \cong \frac{2}{3n+2} \frac{\chi^{2/3}}{A(1-R)^n K_{Ic}^{3/2}} \frac{P_c^{n+\frac{2}{3}}}{P_{\max}^n} \quad (11)$$

In a plot of numbers of cycles to failure versus the maximum load during the fatigue test, the crack growth exponent n can be estimated from the slope of the expected straight line. Application of Equation 11 to the median values of Fig. 2c with the slope of $d(\log N_f)/d(\log P_{\max}) = -5.5$ yields a crack growth exponent of $n = 5.5$. This low value obtained for artificially long cracks is in contrast to the 'natural crack' result of $n = 25$ from [3]. A similar behavior has been observed for tests under quasi-static subcritical crack growth conditions [5–7].

In this context, several reasons are mentioned in [6] as to why differences in n -values may occur:

- natural flaws are often three-dimensional (e.g., pores),
- the flaws may be of the same order of magnitude as the microstructure, where the continuum

mechanics theory of fracture mechanics reaches its limit,

- the R-curve affects small flaws in another way than macrocracks.

For an improved fracture mechanics analysis it is necessary to determine the correct stress intensity factor solution for the tests. Therefore, microscopic observation of cone crack development is needed, and for K-determination the obtained crack path has to be modelled by finite elements. This effort loaded work is still being carried out.

Acknowledgment

The authors would like to thank the Deutsche Forschungsgemeinschaft DFG for financing parts of this work within the SFB 483.

References

1. T. FETT, R. KELLER, D. MUNZ, E. ERNST and G. THUN, *Engng. Fract. Mech.* **79** (2003) 1143.
2. T. FETT, E. ERNST and D. MUNZ, *J. Mater. Sci. Lett.* **21** (2002) 1955.
3. R. NEJMA, K. H. LANG and D. LÖHE, "Ermüdungsverhalten Von Thermisch und Mechanisch beanspruchter Al₂O₃-Keramik", in *Hochbeanspruchte Gleit- und Friktionssysteme auf Basis ingenieurkeramischer Werkstoffe* (Karlsruhe, 2002) p. 177.
4. B. LAWN and T. R. WILSHAW, "Fracture of Brittle Solids" (Cambridge University Press, 1975).
5. T. E. ADAMS, D. J. LANDINI, C. A. SCHUMACHER and R. C. BRADT, *Ceram. Bull.* **60** (1981) 730.
6. K. CHEN and Y. KO, *Amer. Ceram. Soc. Bull.* **67** (1988) 1228.
7. D. MUNZ and T. FETT, "CERAMICS, Failure, Material Selection, Design" (Springer-Verlag, März, 1999).

*Received 2 March
and accepted 11 May 2004*